

**TOWN OF CROSSFIELD
ADDRESSING BYLAW
BY-LAW NO. 2017-08**

Being a Bylaw of the Town of Crossfield in the Province of Alberta to provide for the orderly numbering of parcels of land and buildings within the Town of Crossfield.

WHEREAS under the authority of and subject to the provisions of the Municipal Government Act, Statutes of Alberta, Chapter M-26, and amendments thereto, Town Council may name roads or areas within its boundaries and may assign a number or other means of identification to buildings or parcels of land; and

WHEREAS Town Council may require an owner or occupant of a building or parcel of land to display the identification in a certain manner; and

WHEREAS Town Council deems it necessary to exercise this authority:

NOW, THEREFORE, the Municipal Council of the Town of Crossfield in Council duly assembled hereby enacts as follows that:

SECTION 1: SHORT TITLE

1.0 This bylaw may be cited as the "Addressing Bylaw".

SECTION 2: DEFINITIONS

2.0 In this bylaw the following terms (unless the context specifically requires otherwise) shall have the following meanings:

- a. **"Accessory use"** means a use:
 - i. Which is incidental and subordinate to the principal use of the parcel; and
 - ii. Which is located on the same parcel as the principal use.
- b. **"Address number"** means the civic address of a property which is used; or intended to be used, as part of the address for the property as designated by the Town from time to time which may include combination of numbers and or letters;
- c. **"Council"** means the Municipal Council of the Town of Crossfield;
- d. **"Lane"** includes a private lane, a public lane typically located to the side or rear of a property which provides a secondary means of access to the parcel or parcels;

- e. **"Owner"** means, with respect to a property, the person who is registered under the Land Titles Act as owner of the property;
- f. **"Peace Officer"** means a member of Royal Canadian Mounted Police, or a Bylaw Enforcement Officer;
- g. **"Principal Building"** means a building
 - i. that occupies the major or the central portion of a parcel of land or
 - ii. is the main building among a group of buildings on the parcel of land or
 - iii. constitutes by reason of its use the primary purpose for which the parcel of land is used.
- h. **"Property"** means a parcel of land, a building or a unit or sub-unit within a building;
- i. **"Road"** means land shown as a road on a plan of survey that has been filed or registered in a land titles office or used as a public road;
- j. **"Town"** means the Town of Crossfield and, where the context so requires, means the area contained within the boundaries of the Town of Crossfield.

SECTION 3: NUMBERING

- 3.0 All parcels of land, buildings units and sub-units within buildings obtaining access from a street from other lawful means of as determined by the Development Authority within the town, shall be assigned a civic address by the Development Authority within the following general rules:
- i. Streets shall be numbered or lettered in sequence with existing streets, increasing east to west and south to north when possible.
 - ii. Even numbers shall be placed on the west and north side of street and odd numbers shall be placed on the south and east side of the streets.
 - iii. Where each building cannot be number in succession because of numbering restrictions, the number will follow the sequence of number in the surrounding area to avoid duplication.
- 3.1 The Development Authority is authorized to revise addresses from time to time.
- 3.2 The Development Authority shall keep a record of all addresses assigned to properties pursuant to this bylaw.
- 3.3 All owners of developments consisting of more than one building and using an internal roadway access system shall be responsible for the construction, erection and maintenance of their building address.
- 3.4 Addressing on extensions of existing streets should be consistent with the established pattern, and the endpoint should be double checked in order to avoid duplication.

- 3.5 There should be coordination of addresses between new Plans of Subdivision so that beginning and endpoints do not have duplicate addresses.
- 3.6 Addressing of residential corner lots shall be based on the orientation of the front yard as defined in the Town's current Land use Bylaw; the narrowest portion of the lot determines the front yard.
- 3.7 Residential lots should have only one address assigned to them as there is only one dwelling per lot. If a property consists of a carriage house, up/down duplex, or Mobile Home Park the property shall be addressed with an A & B or unit number (e.g. Unit #1 100 Apple Street, Unit 2 100 Apple Street etc.)
- 3.8 Industrial lots should have only one address assigned to them as there is only one principle building. If a property consists of additional buildings used by other than the property owner, the additional buildings shall be addressed with an A, B, C or unit number (e.g. #100, Bay C, 1234 Lake Drive.)

SECTION 4: DISPLAY OF NUMBERS

- 4.0 An address number shall be allotted by the Town for each new dwelling as and when required.
- 4.1 The owner of a property on which a structure has been erected shall cause the numbers assigned to the property pursuant to this bylaw to be displayed, at all times, at a location plainly visible from the roadway or sidewalk which the property is addressed.
- 4.2 Address numbers are not to be obstructed by trees, shrubs or any ornaments hanging from the property.
- 4.3 No person shall display or permit the displaying of any address number on a property other than the number currently assigned pursuant to this bylaw.
- 4.4 No person shall display, or permit the displaying of any address number on a property other than the number currently assigned pursuant to this bylaw.
- 4.5 The owner of a property which is a construction site and upon which a structure is being erected shall ensure that a temporary address number is displayed at all times in a conspicuous manner so as to be plainly visible from the adjacent roadway, laneway or sidewalk as the case may be.
- 4.6 The owner of a property which has an access to a laneway shall, in addition to complying with section 4.1, shall cause a rear address to be displayed when the property has a rear garage with access from the rear laneway.

SECTION 5: ENFORCEMENT

- 5.0 Peace Officers for the purpose of this bylaw may:
- i. enforce any part of this bylaw within the Town boundary; and
 - ii. access any land or structure at any time for inspection or enforcement activities.
- 5.1 Any Peace Officer who has reasonably and probable grounds to believe that any person has contravened any provisions of this bylaw may issue and serve:
- i. a violation tag allowing payment of the specified penalty to the Town, or;
 - ii. a violation ticket allowing payment according to the provisions of the *Provincial Offences Procedure Act*.
- 5.2 Service of a violation tag will be deemed to be sufficient if it is:
- i. personally served; or
 - ii. served by regular mail to the person's last known mailing address.
- 5.3 If a violation ticket is issued in respect of an offence, the violation ticket may:
- i. specify the penalty amount established for an offence of this bylaw; or
 - ii. require a person to appear in Court without the alternative of making a voluntary payment.
- 5.4 A person who commits an offence may:
- i. if a violation ticket is issued in respect of the offence, and
 - ii. if the violation ticket specifies the fine amount established for the offence.
- Make a voluntary payment equal to the specified penalty by delivering the violation ticket and the specified penalty to the Provincial Courthouse specified on the violation ticket.

SECTION 6: SEVERABILITY

- 6.0 Each provision of this bylaw is independent of all other provisions. If any such provision is declared invalid by a Court of competent jurisdiction, all other provisions of this bylaw will remain valid and enforceable.
- 6.1 It is the intention of the Council of the Town of Crossfield that all offences created pursuant to this bylaw by constructed and considered as being strict liability offences.

SECTION 7: EFFECTIVE

7.0 The Town of Crossfield Addressing Bylaw may, from time to time be amended by Council.

7.1 This Bylaw shall come into full force and effective upon third and final reading.

Given first reading this 20th day of June, 2017.

Given second reading this 20th day of June 2017.

Given third and final reading this 20th day of June 2017.



Mayor Anderson



CAO Ken Bosman

**Town of Crossfield
Addressing Bylaw 2017-08**

Schedule "A" Voluntary Payment

		1st Offence	2nd Offence
Section 4.1	Numbers assigned visibly from the roadway or sidewalk	\$50.00	\$100.00
Section 4.2	Address number obstructed by trees, shrubs or any ornaments hanging from the property	\$50.00	\$100.00
Section 4.4	displaying of addresses on a property other than the number currently assigned	\$100.00	\$150.00
Section 4.5	construction site addressing	\$50.00	\$100.00
Section 4.6	Rear yard garage with access from the rear laneway	\$50.00	\$100.00

**Town of Crossfield
Addressing Bylaw 2017-08**

Schedule "B" Street Addressing

FIGURE 1 - Exception to the Even vs. Odd Rule

In order to be consecutive and uniform, some situations cannot adhere to the "even on the north and west and odd on the south and east" rule. This situation occurs with small courts and U-shaped crescents (Figure 1)

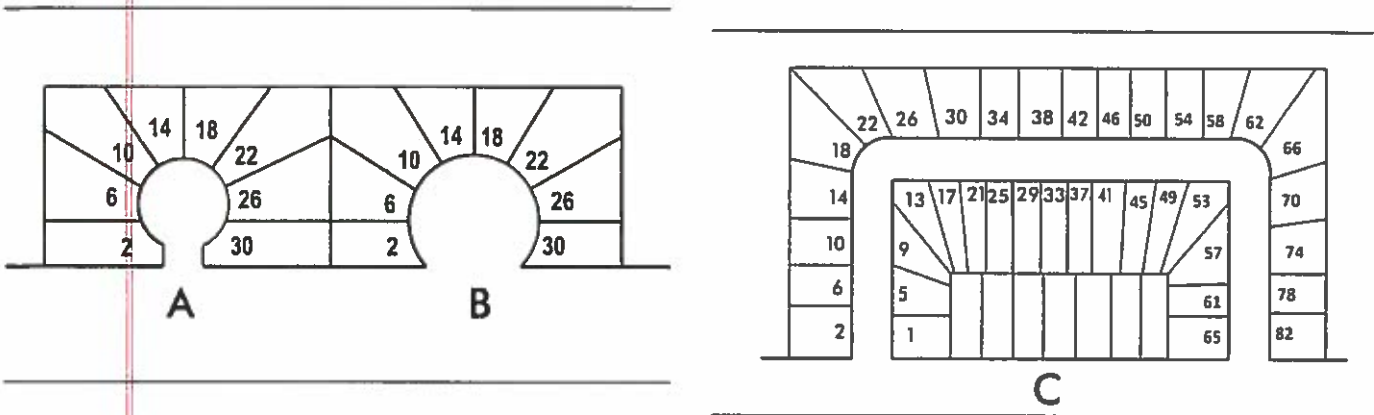
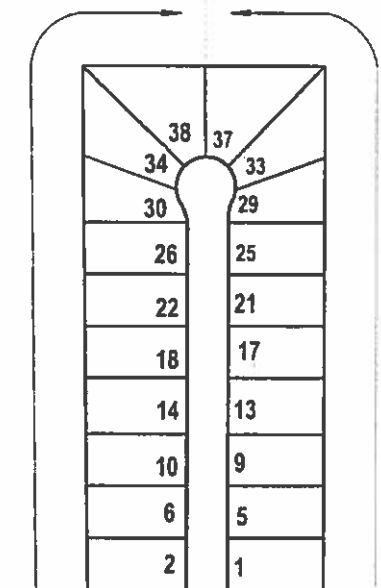

FIGURE 2 - Addressing on a Court

In the case of a regular court where there is more than one lot before the bulb, the even-odd rule can apply, with the numbers meeting at the center of the bulb



NOTE: Arrow indicate direction of numbering

FIGURE 3 - Number on a U-shaped Crescent

In the case of a long, U-shaped crescent, the even-odd rule can also apply:

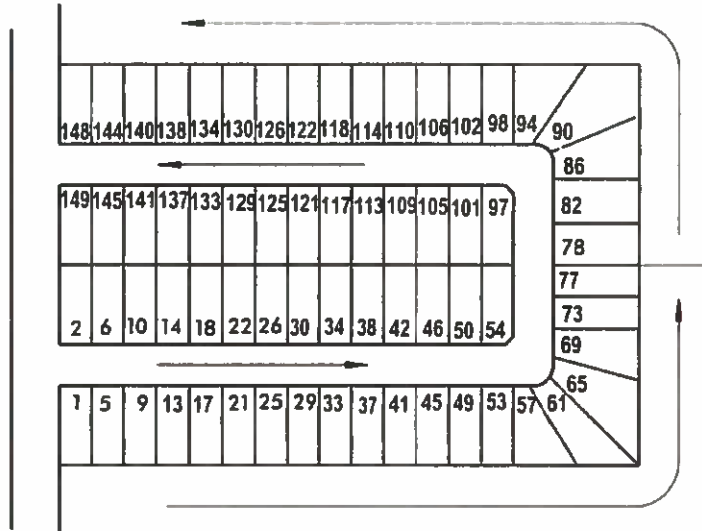

NOTE: Arrows indicate direction of numbering